



# 100% ELECTRIC

## KEY SPECIFICATIONS

- Battery Powered: 24kWh - 4hr / 42kWh - 6hr
- Charge Time: 8hr Standard / 4hr Fast Charge
- Continuous Power: 40.5kW
- Height to Hinge Pin: 144 7/8" / 3680mm
- Hydraulic Flow Rate: 19 GPM / 78 l/min
- Overall Machine Width: 66 1/2" (1688mm)  
70 1/2" (1788mm)
- Operating Weight: EX227R- 8150lbs (3700kg)  
EX245R - 8750lbs (3975kg)
- HYD OR Electric Attachments
- Up & Over Cabin Door
- Telematics Option
- 3 Traction Power Modes
- 3 Hydraulic Power Modes



## KEY FEATURES

The 100% battery powered EXVO EX2 significantly lowers operating costs and carbon emissions, aiding access to low-carbon projects. The new Up and Over door allows easy access to the cabin while increasing visibility and enhancing operator comfort.

With ZERO exhaust emissions, the EXVO EX2 enables silent operation on the jobsite, reducing noise pollution, and allowing the ability to work night shifts with little to no disturbance to residents.

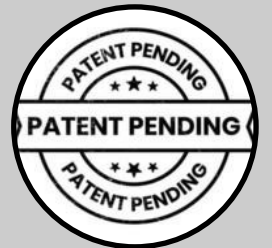

**PATENT PENDING**

United Kingdom Application No 2312690.7



# EX2 SKID STEER

**EX227R**

**EX245R**



**100% ELECTRIC  
SKID STEER**

**STANDARD FEATURES**

- Front & Rear Work Lights
- Horn & Reversing Buzzer
- ISO Joysticks
- Operator Keypad Access
- Mesh Cabin Sides
- Front Auxiliary Hydraulics
- X3 Power Modes
- X3 Hydraulic Modes
- Traction Speed Limit Settings
- Cabin Cleanout Plate
- Cabin USB Connection
- X4 Lift Points/ Tie Down Points
- Removable Battery

**OPTIONAL FEATURES**

- Fully Enclosed Cabin  
c/w Up & Over Door
- Cabin Heater
- Air Conditioning
- Reverse Light Kit
- Reversing Camera
- Front Auxiliary Electric Connection  
(X-TACH)
- Self-Levelling Boom
- Boom Suspension
- Telematics Kit
- Flashing Beacon
- Bluetooth Radio



**SCAN TO VISIT OUR  
WEBSITE**

	IMPERIAL	METRIC	IMPERIAL	METRIC
Operating Capacity (ROC)	1870lbs	850kg	2750lbs	1250kg
Tipping Capacity	3740lbs	1700kg	5500lbs	2500kg
Operating Weight	8150lbs	3700kg	8750lbs	3975kg
A. Height to Hinge Pin	146"	3708mm	146"	3708mm
B. Overall Height to Top of ROPS	86 ¼"	2190mm	86 ¼"	2190mm
C. Dump Reach at Full Height	19 ⅞"	487mm	19 ⅞"	487mm
D. Overall Length with Bucket	139 ½"	3543mm	139 ½"	3543mm
E. Overall Length without Bucket	105"	2668mm	105"	2668mm
F. Overall Width without Bucket	66 ½"	1688mm	70 ½"	1788mm
G. Overall Width with Bucket	68"	1727mm	74"	1880mm
H. Dump Angle at Full Height	32°	32°	32°	32°
I. Dump Height	118 ⅞"	3002mm	118 ⅞"	3002mm
J. Rollback Angle at Ground Level	32°	32°	32°	32°
K. Ground Clearance	10 ¼"	260mm	10 ¼"	260mm
L. Departure Angle	27°	27°	27°	27°
M. Wheelbase	47 ½"	1210mm	47 ½"	1210mm
N. Clearance Circle - Front Bucket	90 ½"	2300mm	90 ½"	2300mm
O. Clearance Circle - Rear	58"	1472mm	58"	1472mm
Hydraulic Flow Rate	19GPM	78 L/min	19GPM	78 L/min
Tyres	10x16.5 HD	10x16.5 HD	12x16.5 HD	12x16.5 HD
Nominal Power	40.5kW	40.5kW	40.5kW	40.5kW
Maximum Power	120kW	120kW	120kW	120kW
Battery Capacity - Run Time	24kWh—4hr run time		42kWh—6hr run time	
Charging Options	3Ph 4 Hr Charger 1Ph/3Ph 8 Hr Charger		3Ph 4 Hr Charger 1Ph/3Ph 8 Hr Charger	

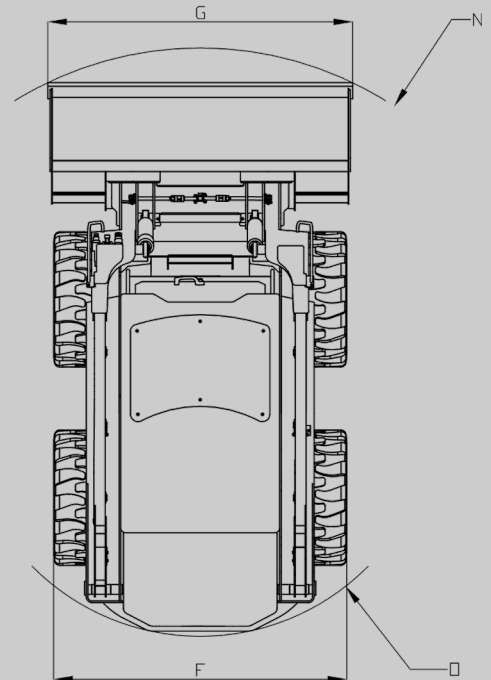
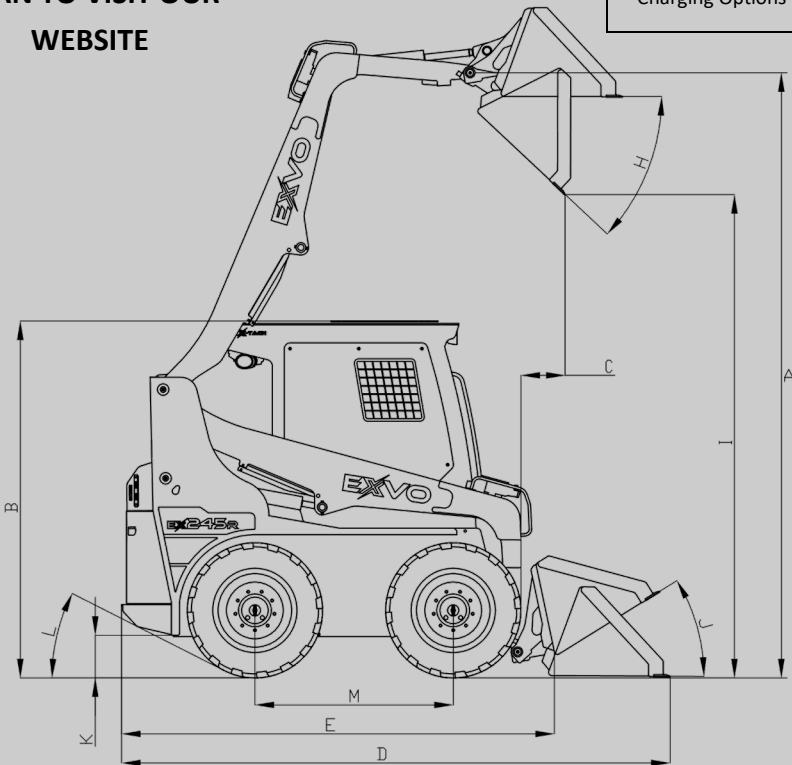

EXVO HAS A POLICY OF CONTINUOUS PRODUCT DEVELOPMENT AND RESERVES THE RIGHT TO ALTER SPECIFICATIONS WITHOUT PRIOR NOTICE. SPECIFICATIONS AND/OR DIMENSIONS MAY VARY FROM THOSE ILLUSTRATED IN SOME COUNTRIES.

