



100% ELECTRIC

KEY SPECIFICATIONS

- Battery Powered: 60kWh - 4hr / 70kWh - 6hr
- Charge Time: 10hr Standard / 4hr Fast Charge
- Continuous Power: 60.5kW
- Height to Hinge Pin: 130.5" / 3316mm
- Hydraulic Flow Rate: 19 GPM / 78 l/min
- Operating Weight: 60kWh - 12491lbs (5665kg)
70kWh - 13152lbs (5965kg)
- Overall Machine Width: 16" Track
74.5" (400mm Track—1890mm)
- HYD OR Electric Attachments
- Up & Over Cabin Door
- Telematics Option
- 3 Traction Modes
- 3 HYD Modes



KEY FEATURES

The 100% battery powered EXVO TX4 significantly lowers operating costs and carbon emissions, aiding access to low-carbon projects. The new Up and Over door allows easy access to the cabin while increasing visibility and enhancing operator comfort.

With ZERO exhaust emissions, the EXVO TX4 enables silent operation on the jobsite, reducing noise pollution, and allowing the ability to work night shifts with little to no disturbance to residents.



PATENT PENDING

United Kingdom Application No 2312690.7



TX4 COMPACT TRACK LOADER

TX475V

TX487V



100% ELECTRIC COMPACT TRACK LOADER

STANDARD FEATURES

- Front & Rear Work Lights
- Horn & Reversing Buzzer
- ISO Joysticks
- Operator Keypad Access
- Mesh Cabin Sides
- Front Auxiliary Hydraulics
- X3 Traction Modes
- X3 Hydraulic Modes
- Traction Speed Limit Settings
- Cabin Cleanout Plate
- Cabin USB Connection
- X4 Lift Points/ Tie Down Points
- Removable Battery

OPTIONAL FEATURES

- Fully Enclosed Cabin
c/w Up & Over Door
- Cabin Heater
- Air Conditioning
- Reverse Light Kit
- Reversing Camera
- Front Auxiliary Electric Connection
- Electric Quick Attach Headstock
(X-TACH)
- Self-Levelling Boom
- Boom Suspension
- Float Function
- Telematics Kit
- Flashing Beacon
- Bluetooth Radio



SCAN TO VISIT OUR
WEBSITE

	IMPERIAL	METRIC	IMPERIAL	METRIC
Operating Capacity (35% ROC)	2750lbs	1250kg	3352lbs	1520kg
Tipping Capacity	7857lbs	3571kg	9576lbs	4343kg
Operating Weight	12491lbs	5665kg	13153bs	5965kg
A. Height to Hinge Pin	130 ½"	3316mm	130 ½"	3316mm
B. Overall Height to Top of ROPS	90 ¼"	2290mm	90 ¼"	2290mm
C. Dump Reach at Full Height	36"	914mm	36"	914mm
D. Overall Length with Bucket	146 ½"	3726mm	146 ½"	3726mm
E. Overall Length without Bucket	112 ¼"	2851mm	112 ¼"	2851mm
F. Overall Width without Bucket	69"	1750mm	74 ½"	1890mm
G. Overall Width with Bucket	72"	1830mm	78"	1980mm
H. Dump Angle at Full Height	36.5°	36.5°	36.5°	36.5°
I. Dump Height	99½"	2530mm	99½"	2530mm
J. Rollback Angle at Ground Level	28°	28°	28°	28°
K. Ground Clearance	10"	250mm	10"	250mm
L. Departure Angle	28°	28°	28°	28°
M. Track Ground Contact Length	60"	1520mm	60"	1520mm
N. Clearance Circle - Front Bucket	92 ¼"	2342mm	92 ¼"	2342mm
O. Clearance Circle - Rear	63 ¼"	1606mm	63 ¼"	1606mm
Hydraulic Flow Rate	19GPM	78 L/min	19GPM	78 L/min
Track Width	12 ½"	320mm	16"	400mm
Nominal Power	60.5kW	60.5kW	60.5kW	60.5kW
Maximum Power	120kW	120kW	120kW	120kW
Battery Capacity - Run Time	60kWh—4hr run time		70kWh—6hr run time	
Charging Options	3Ph 4 Hr Charger 1Ph/3Ph 10 Hr Charger		3Ph 4 Hr Charger 1Ph/3Ph 10 Hr Charger	

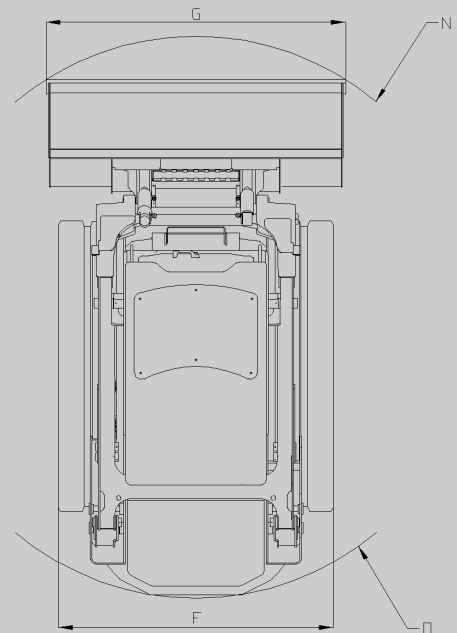
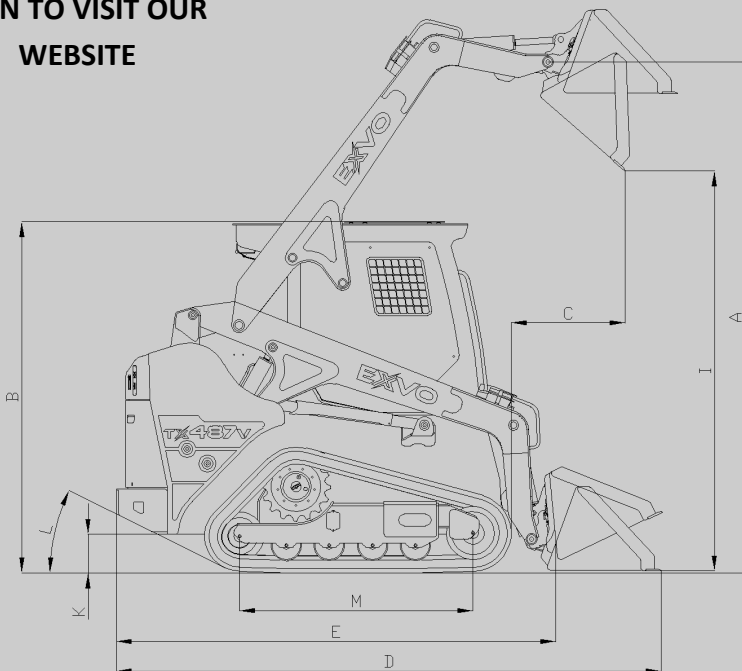

EXVO HAS A POLICY OF CONTINUOUS PRODUCT DEVELOPMENT AND RESERVES THE RIGHT TO ALTER SPECIFICATIONS WITHOUT PRIOR NOTICE. SPECIFICATIONS AND/OR DIMENSIONS MAY VARY FROM THOSE ILLUSTRATED IN SOME COUNTRIES.